



32 DEEPSEA DETAILS

Hydraulic steering

Coronel 32

Deepsea

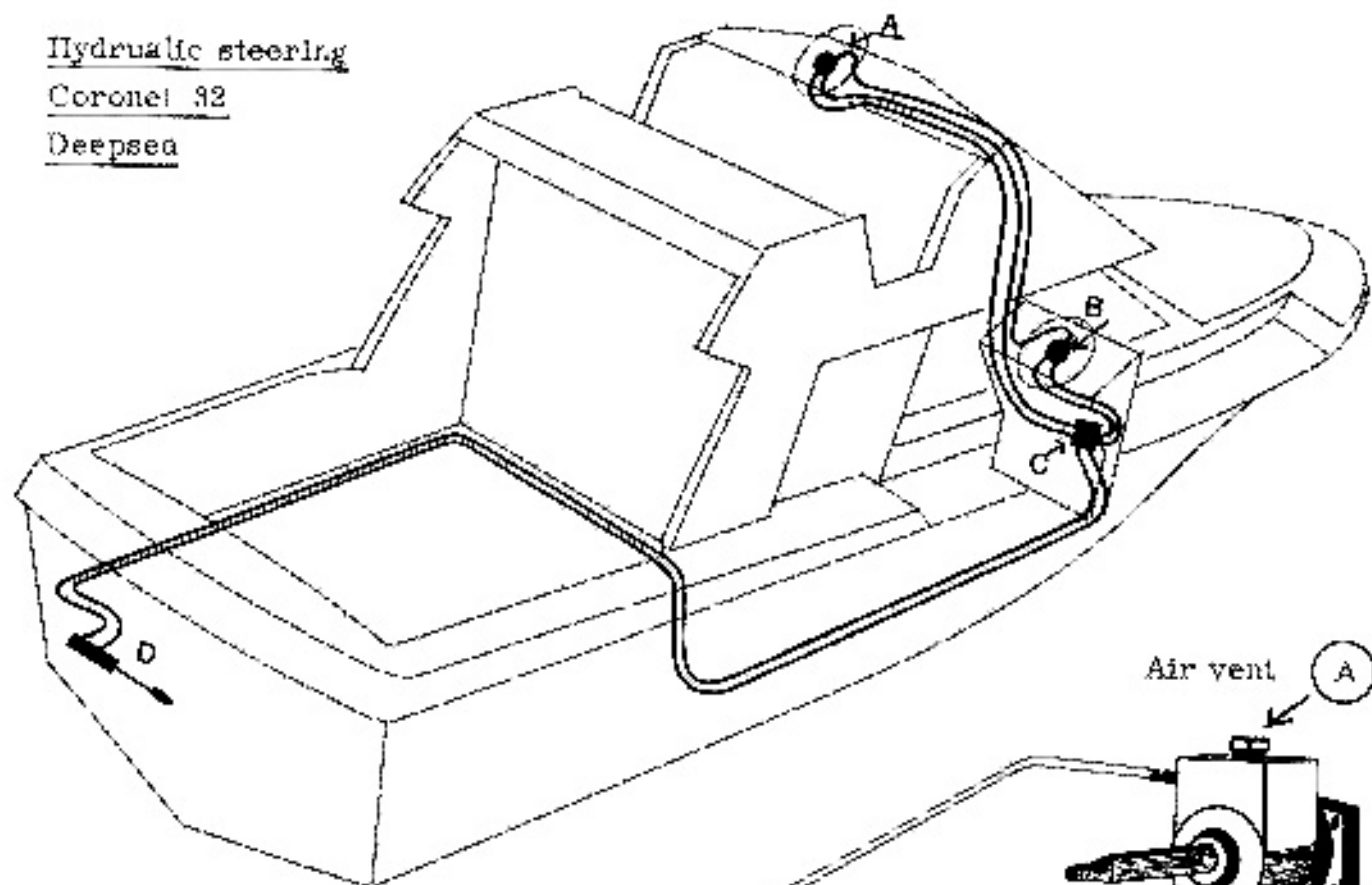

The steering gear in the 32' Deepsea and 24' Family Flybridge is hydraulic. See flow diagram.

You must be sure that the reservoir on the flybridge steering pump is at least half-filled with oil. During the sailing season you should check this for every 100 hours of sailing and refill, if necessary.

Use Esso Nuto H 44 or similar oil.

To check and refill you must take off the flybridge steering pump this way:

Take off the steering wheel (turn center toak- and steelnut anticlockwise). Loosen the four nuts under the pump house, and take out the house. Hold the pump in an upright position and take off the air vent fitting.

Check oil level and refill.

Mount steering pump and wheel again.

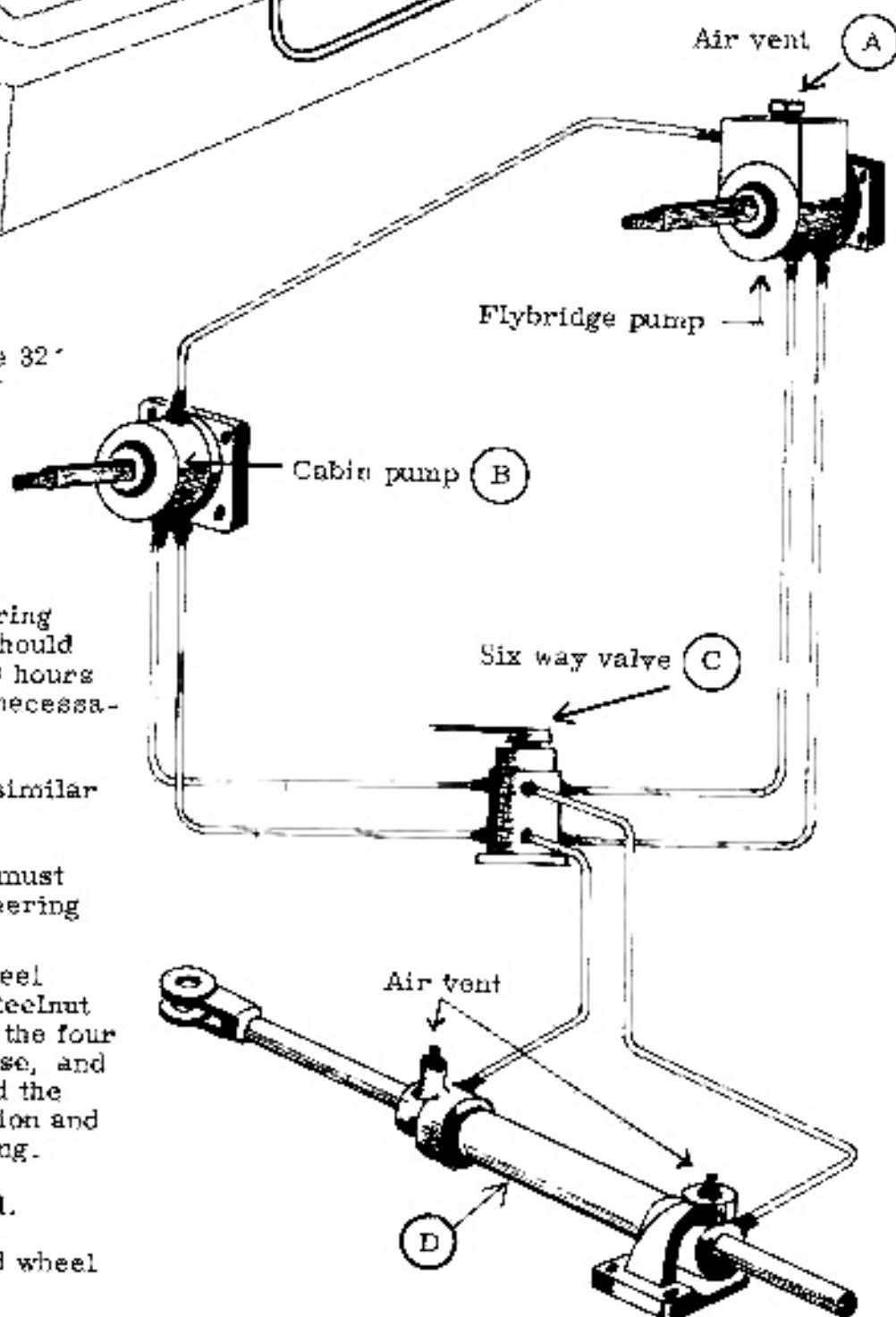

FUEL TANK SYSTEM IN A TWIN ENGINE 32 DRIFTSEA.

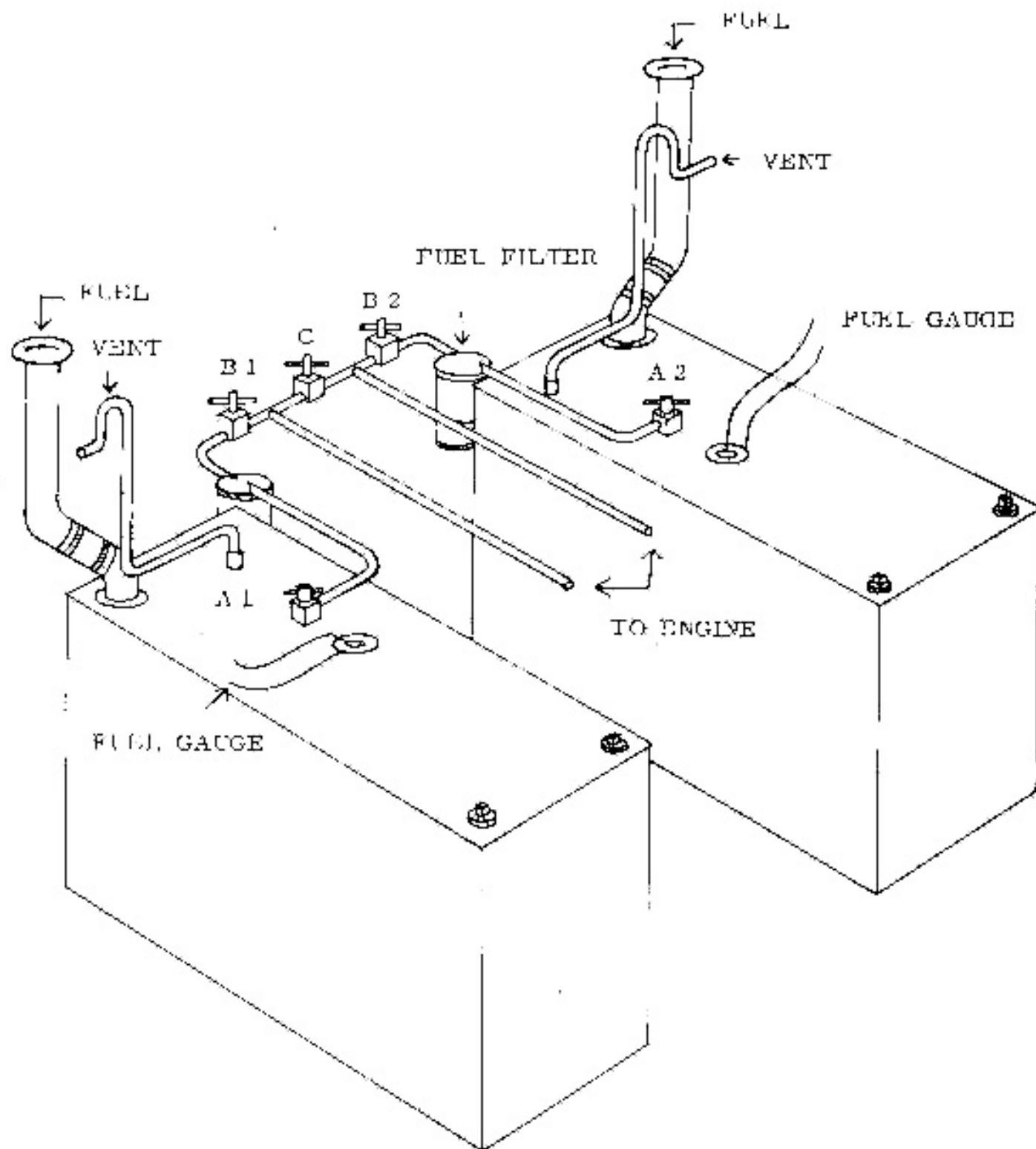

When all the fuel-cocks A 1, A 2, B 1, B 2, and C are open both engines are fed from both fuel tanks. When A 1, A 2, B 1, B 2 are open but C turned off the port engine is fed from A 1 and the star-board engine from A 2. When A 1, A 2, B 1, and C are open whilst B 2 is closed both engines are fed from A 1, and when A 1, A 2, B 2 and C are open whilst B 1 closed both engines are fed from A 2.

1.

The table is completely out of your way under the galley section and secured by a screw in the floor.



2.

If you only want a small table, you can just fold out one of the table flaps.

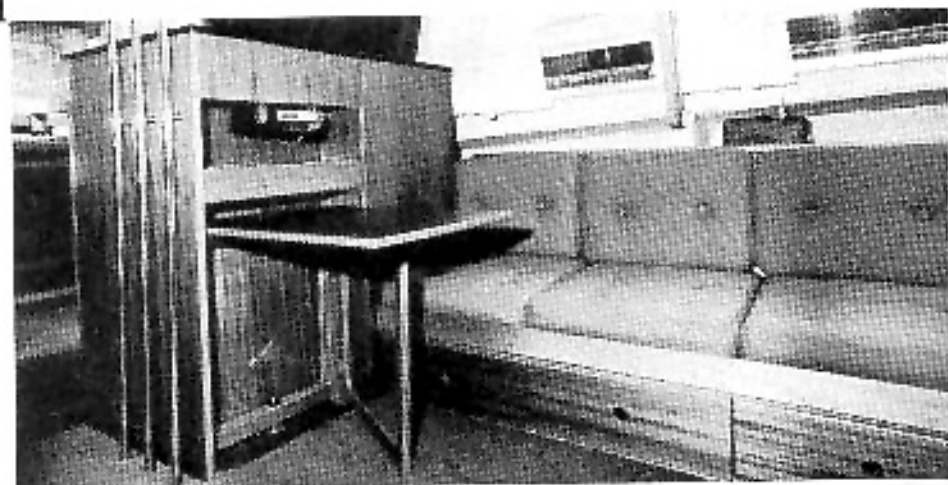

3.

For eating you fold out the table completely and secure it by a screw in the floor.

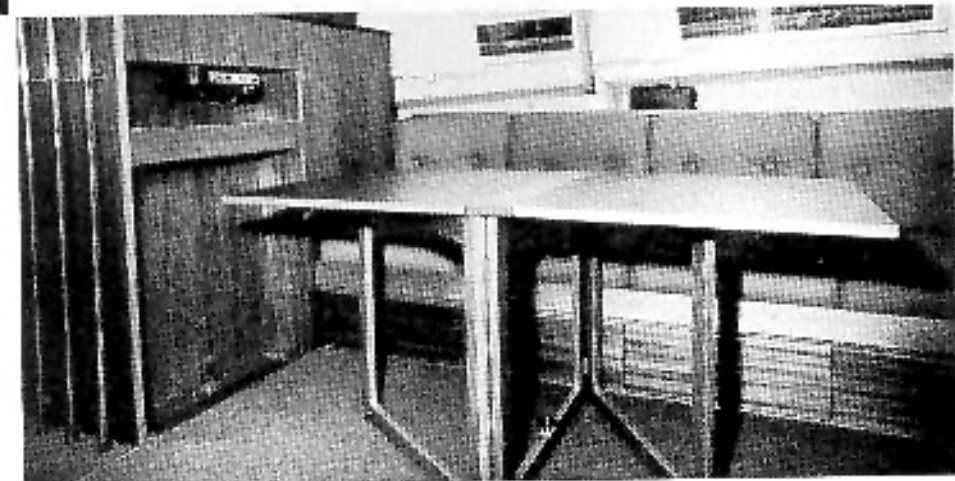

4.

You can take the table out in the cockpit, too.

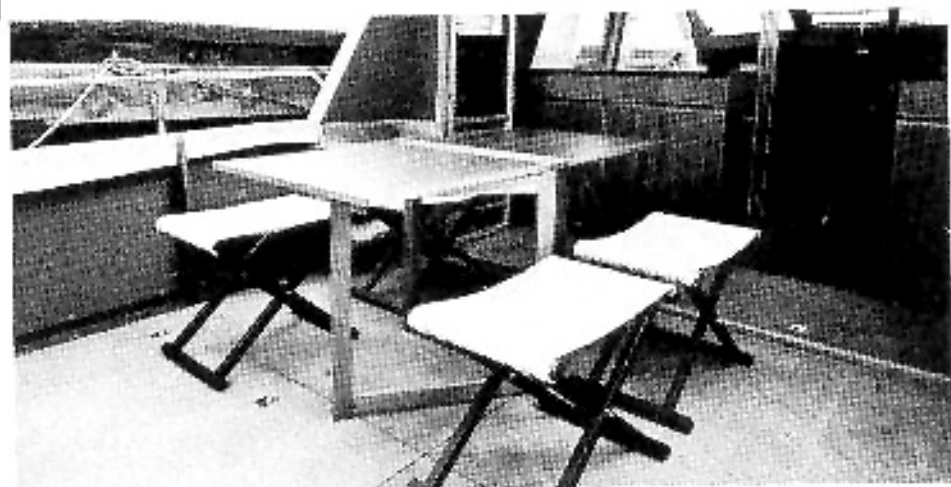

1.

The sofa can be converted into a double berth.



2.

Pull out the front edge of the sofa. Two supporting legs are located under the seat.

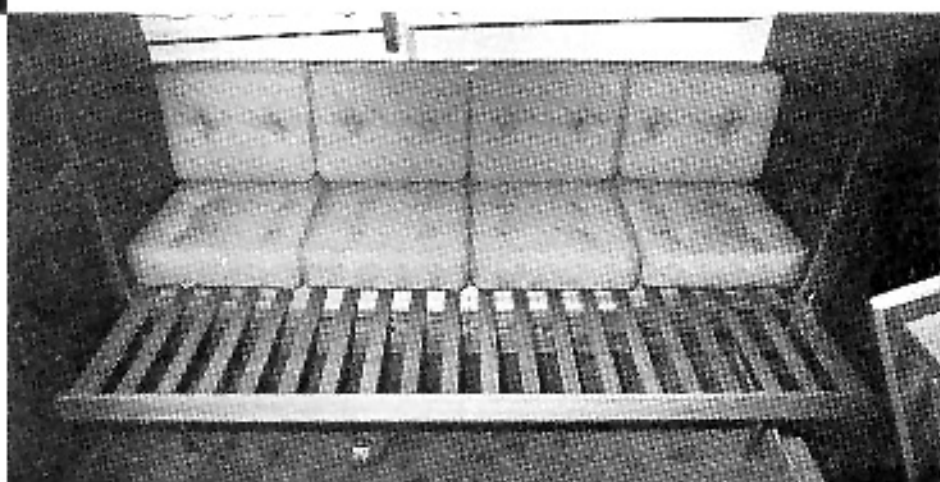

3.

Place the back cushions and the two small extra cushions as shown on the photo. (This is how to do it when you only want to use the double berth and not the extra berth on the starboard side)

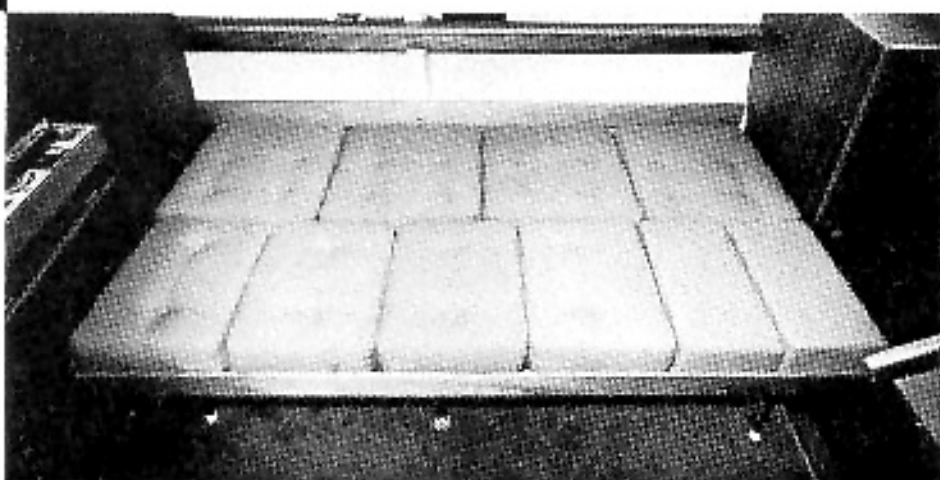

4.

When using the cushion-folding chair as a mattress you must unzip the back-rest section - turn it around and place it next to the other cushion with a cut side.

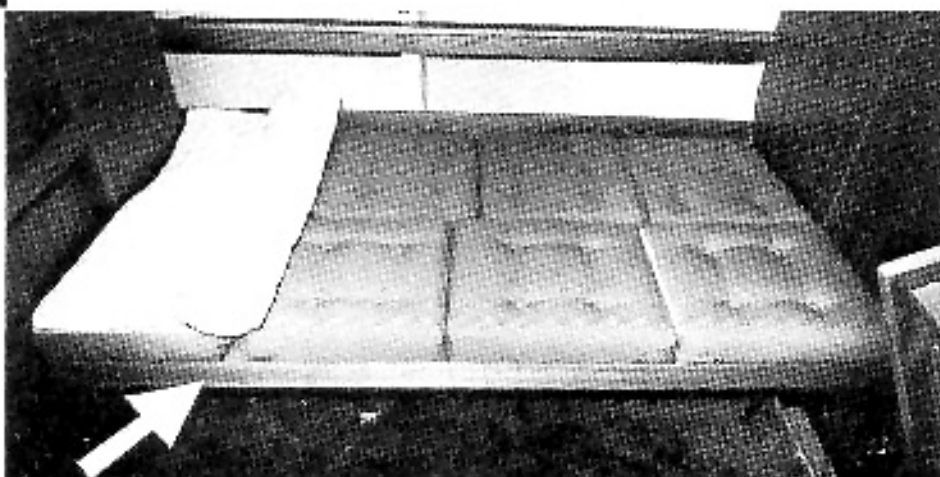

1.

The starboard side of the cabin can also be converted into a berth.

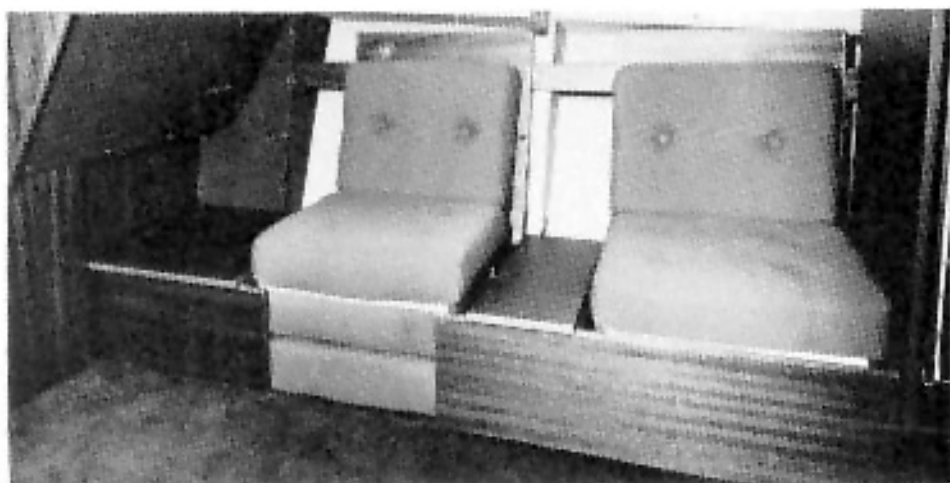

2.

You lift up the two cushion-folding chairs.

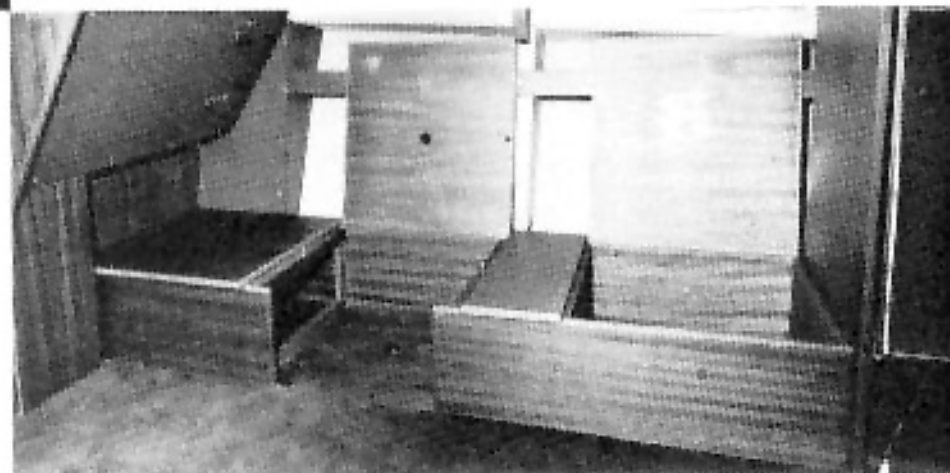

3.

Fold down the two hinged flaps.

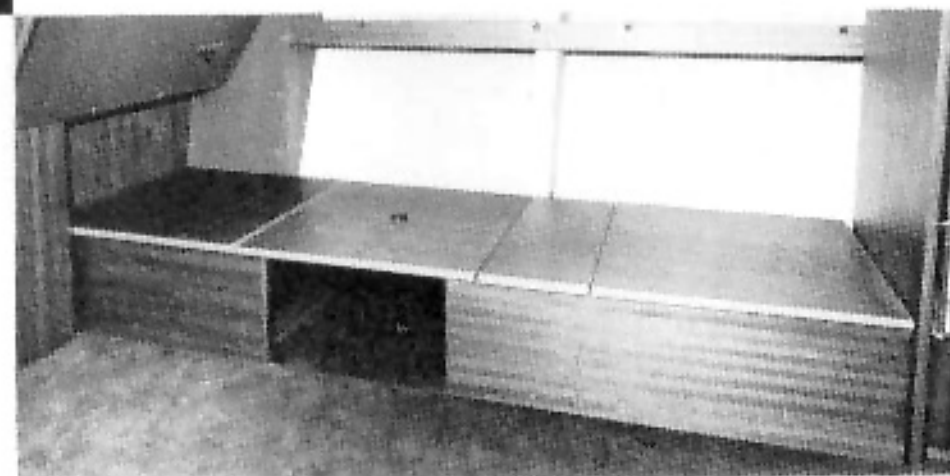

4.

Unzip the backrest cushion section - place the mattress on the boards and add one of the small cushions as shown.

(To avoid the mattress from slipping a thin sheet of foam rubber may be placed between the mahogany and the mattress.)

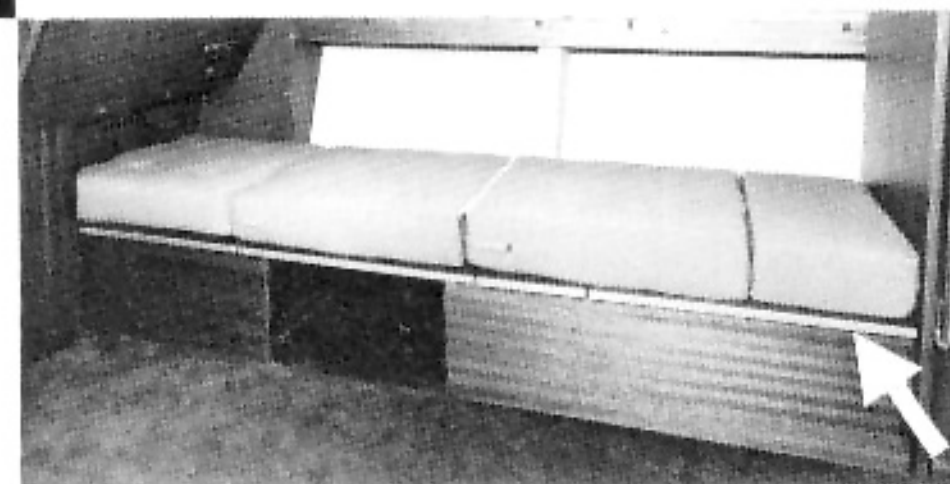

1.

The cushion-folding chairs in starboard side may be placed like this for better view when cruising.



3.

Or they might be used like this.



3.

The two small extra cushions as rest for the back of the head.

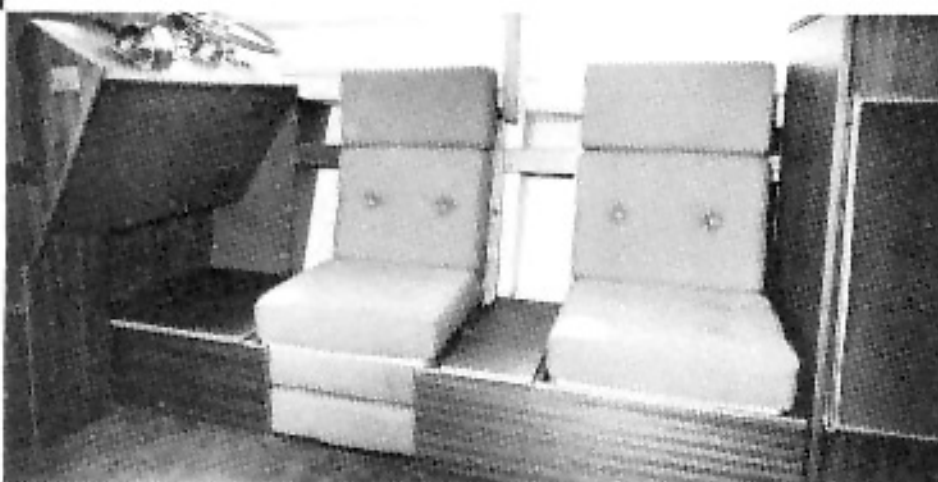

4.

The folding chair is made of four separate cushions zipped together.

They are perfect as sun-mattress in the cockpit too.

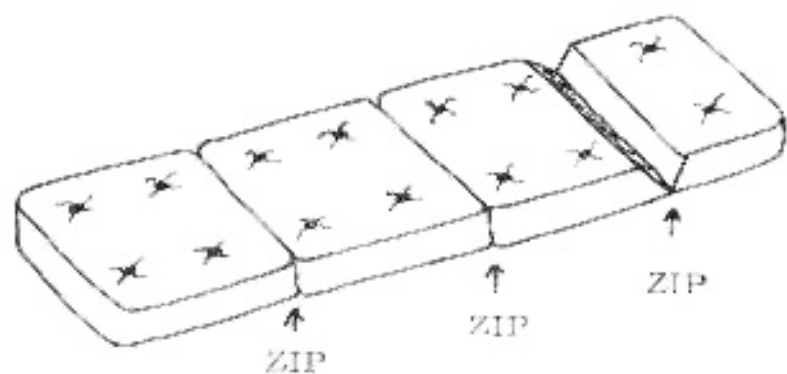

1.

If you want to stand up steering the cushion-folding chair must be removed. There is stowing room under the boxes as shown.

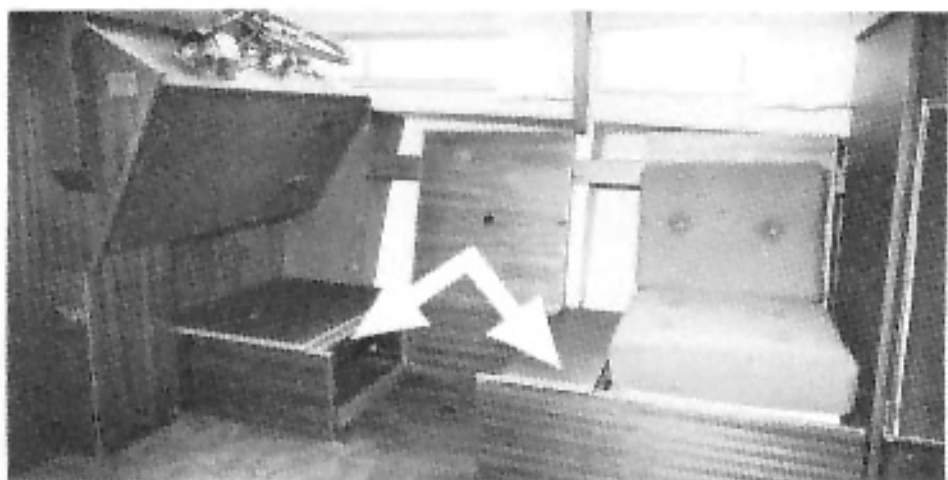

2.

If you prefer to be seated while navigating fold down the hinged flap and put the aluminium tube supporting the pilot seat through the hole in the hinged flap and in the floor-board,



3.

Under the floor is a big room for stowing.



4.

In the galley under the green trays are two big rooms for stowing.



In order to secure the tableware when cruising, the Deepsea galley is especially designed to contain the items illustrated here. The melamine tableware from Fiskars, Finland, is durable, break and chip resistant.

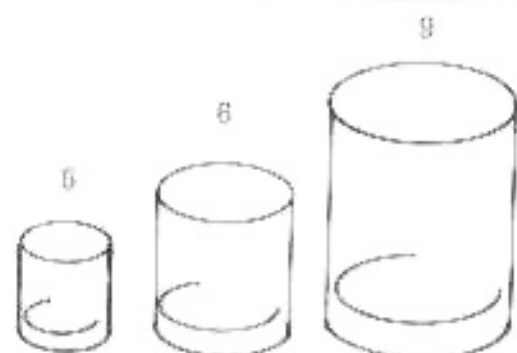

Caravelle glass

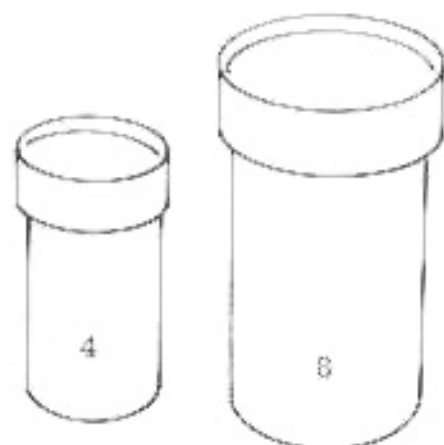

Boxes for coffee, sugar etc.

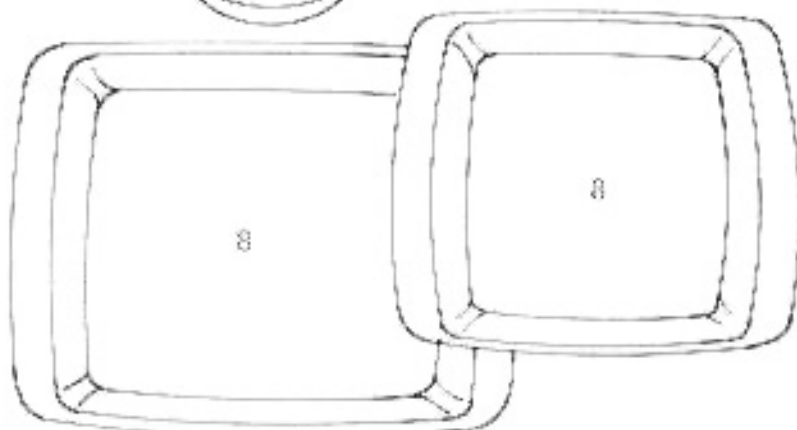
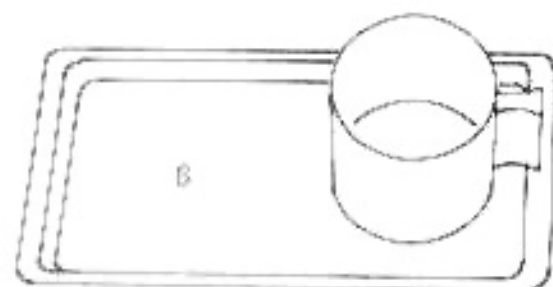
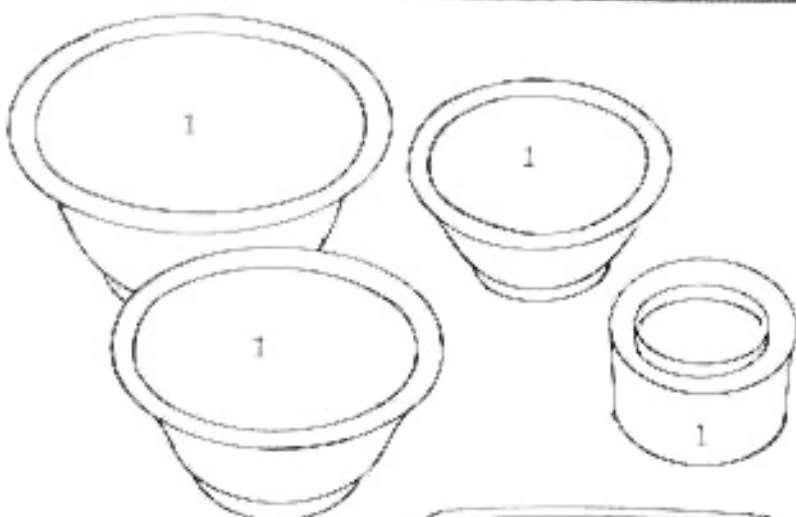

You can order this as a complete set from Botved Boats A/S.

It is important that you remember always to secure the doors either in a completely open A half-closed B or a closed position.

Never open two sections of the doors as one big door, as you might damage the doors and the wood-work,

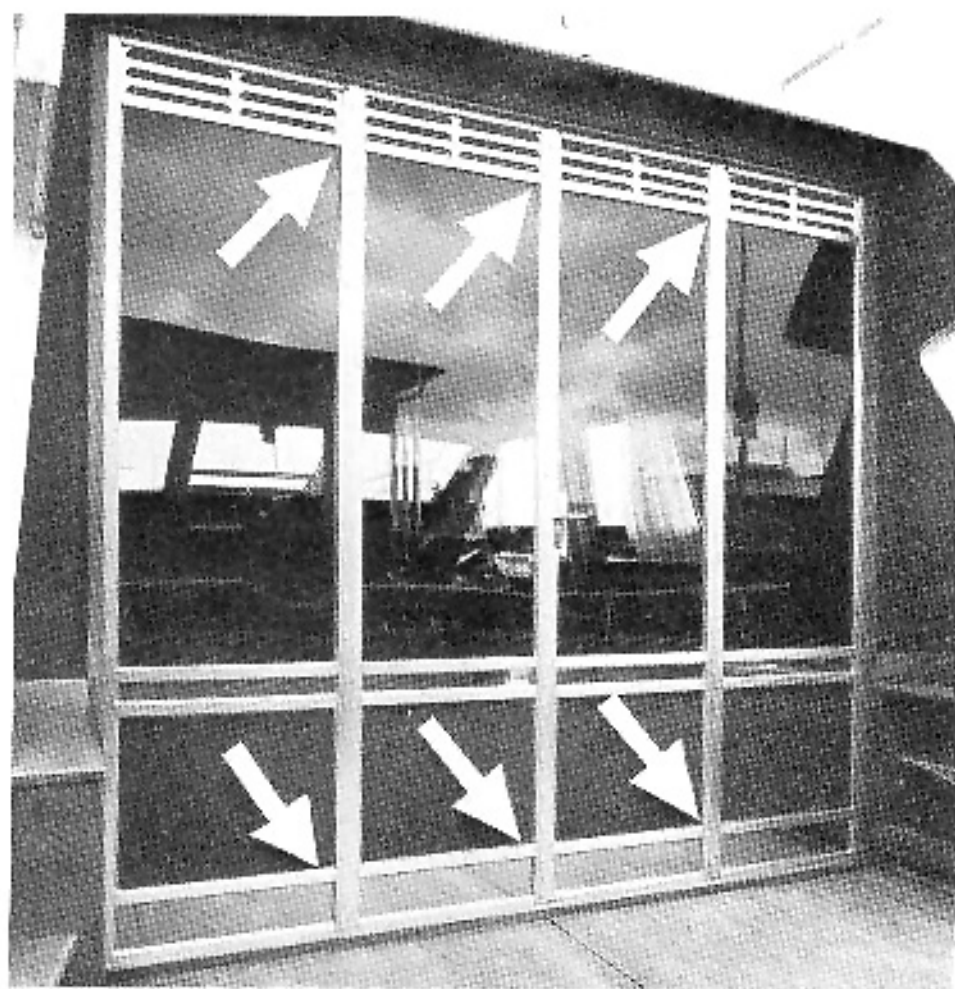

The arrows show all the parts of the door that you must remember to secure.

A.

B.

B.

